

LINEA VITA TEMPORANEA
cod. SELVP200



SEKURE Srl
VIA T. EDISON, 4 - 35012 CAMPOSAMPIERO (PD)
Tel. (+39) 049.87.407.66 - Fax. (+39) 049.87.401.12
info@sekure.it - www.sekure.it

Descrizione:

Dispositivo anticaduta temporaneo costituito da due pali in alluminio di altezza 2 m, controventati al trave a Y mediante utilizzo delle apposite piastre, uniti tra loro mediante linea vita provvisoria in cl. B.

Dispositivo testato per l'utilizzo di massimo 2 operatori alla volta agganciato sul punto di ancoraggio.

Particolari torretta

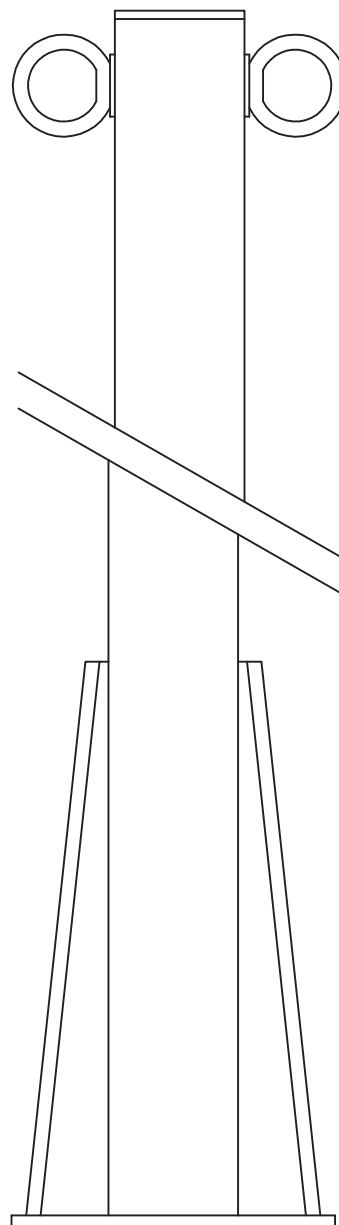
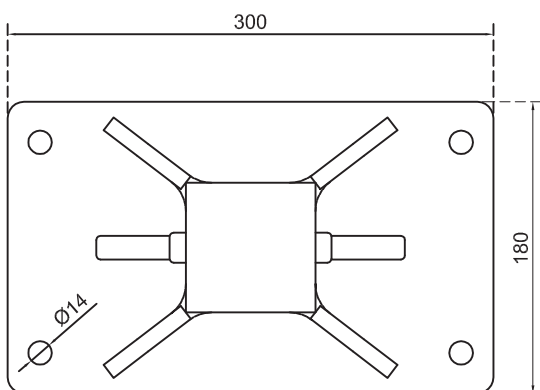

Particolare piastra per tirante

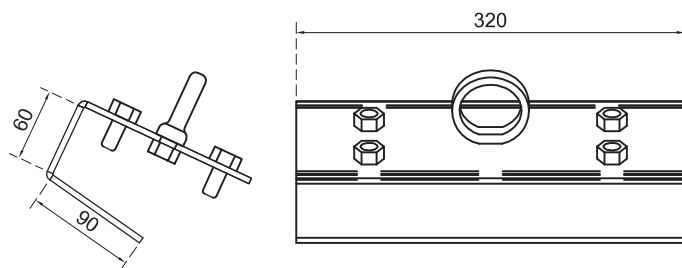

Schema di installazione

Vista frontale

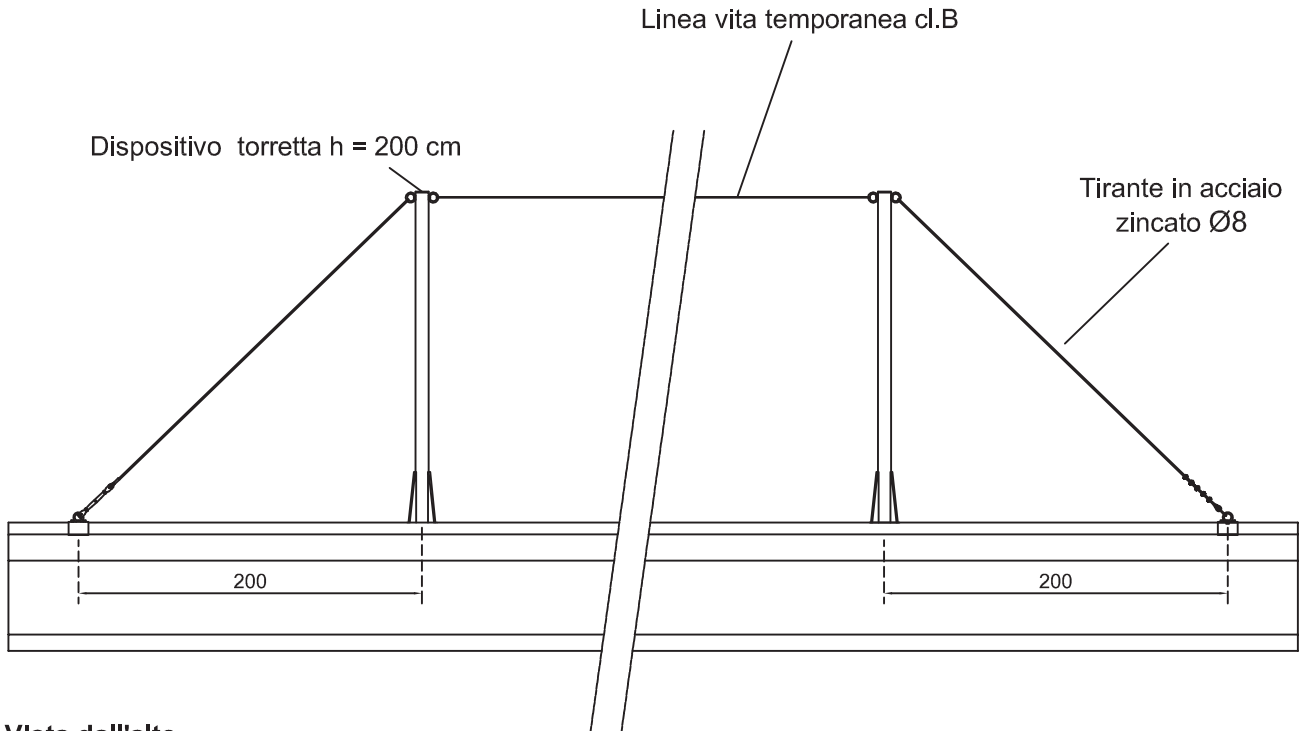

Vista dall'alto

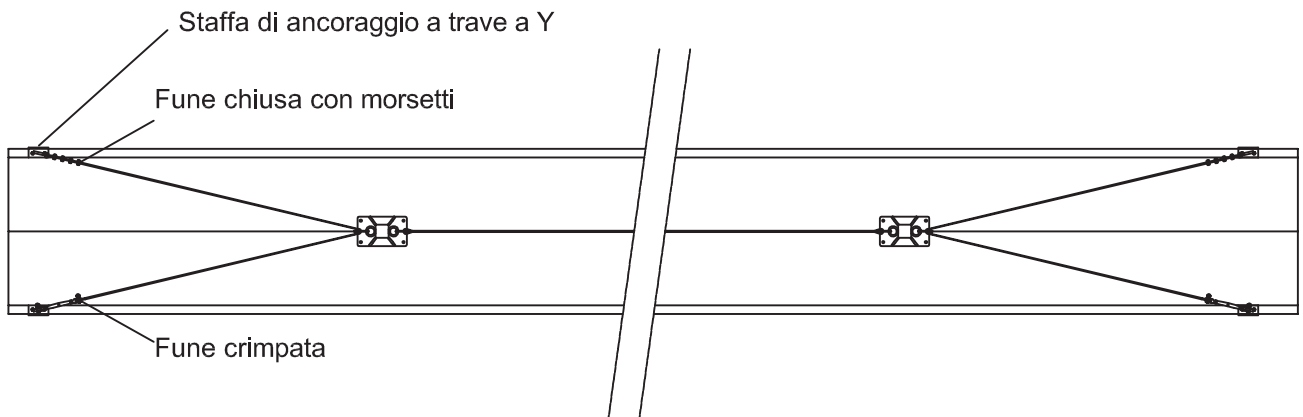

Foto esplicative

